

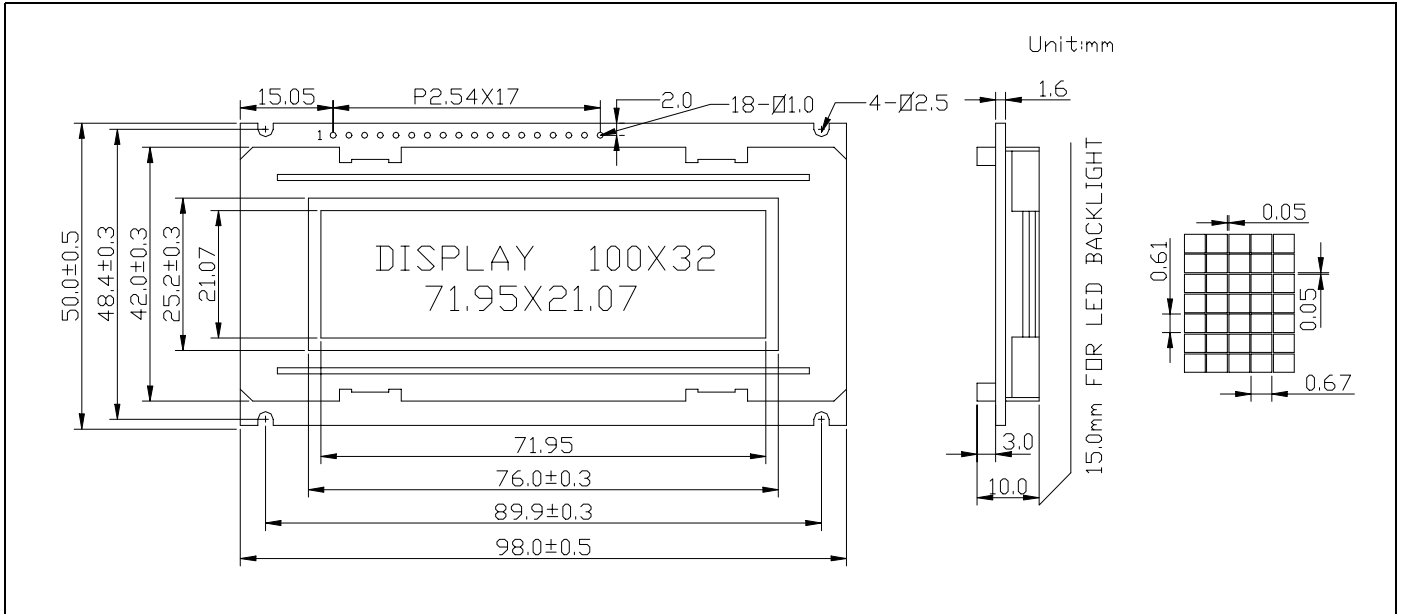

JM10032A

100DOTS×32DOTS
1/32 DUTY,1/7 BIAS

1 EXTERNAL DIMENSION



2 MECHANICAL DATA

ITEM	SPECIFICATION	UNIT
Module Size (W×H×T)	98.0×50.0×10.0(LED:15.0)	mm
Viewing Area (W×H)	76.0×25.2	mm
Number of Dots(W×H)	100×32	dots
Dot Pitch (W×H)	0.72×0.66	mm
Dot Size(W×H)	0.67×0.61	mm

5 ABSOLUTE MAXIMUM RATINGS

PARAMETER	SYMBOL	MIN.	MAX.	UNIT
Supply Voltage	Vdd	-0.3	7	V
LCD Supply Voltage	Vee	Vdd-13.5	0	V
Input Voltage	Vr	-0.3	Vdd+0.3	V
Operating Temperature	Top	0	50	°C
Storage Temperature	Tstg	-20	70	°C

3 PIN CONNECTIONS

PIN	SYMBOL	SIGNAL DESCRIPTION
1	Vss	GND
2	Vdd	Power Supply
3	Vee	Power Supply for LCD
4	A0	H=Display data, L=Instruction
5	R/W	Read/Write Read when "H", Write when "L"
6	E1	Enable for IC1
7	E2	Enable for IC2
8	NC	No connection
9to16	DB0 to DB7	Data Bus for 8bit Mode
17	A	Anode of LED Unit
18	K	Cathode of LED Unit

6 ELECTRICAL CHARACTERISTICS(Ta=25°C)

ITEM	SYMBOL	CONDITION	MIN.	TYP.	MAX.	UNIT
Supply Voltage(logic)	Vdd-Vss	-	4.5	5.0	5.5	V
Supply Current(logic)	Idd	Vdd=5.0	-	1.47	-	mA
Driving Current(LCD)	Iee	Vee=-4.2	-	1.46	-	mA
Driving Voltage(LCD)	Vdd-Vee	-	-	9.2	-	V
Input Voltage "H"	V _{IH}	H	0.8Vdd	-	Vdd	V
Input Voltage "L"	V _{IL}	L	Vss	-	0.8	V
Output Voltage "H"	V _{OH}	H	2.4	-	-	V
Output Voltage "L"	V _{OL}	L	-	-	0.4	V

4 BLOCK DIAGRAM

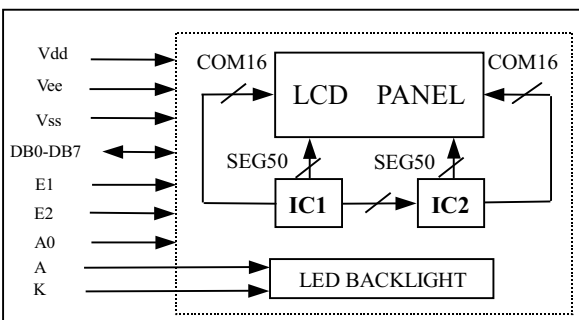

7 BOTTOM BACKLIGHT CHARACTERS(Ta=25°C)

PARAMETER	SYMBOL	CONDITION	MIN.	TYP.	MAX.	UNIT
Supply Voltage	V _{LED}	-	-	4.1	-	V
LED Forward Consumption Current	I _f	Ta=25°C V _f =4.1V	-	210	-	mA
LED Allowable Dissipation	P _d	-	-	880	-	mW