

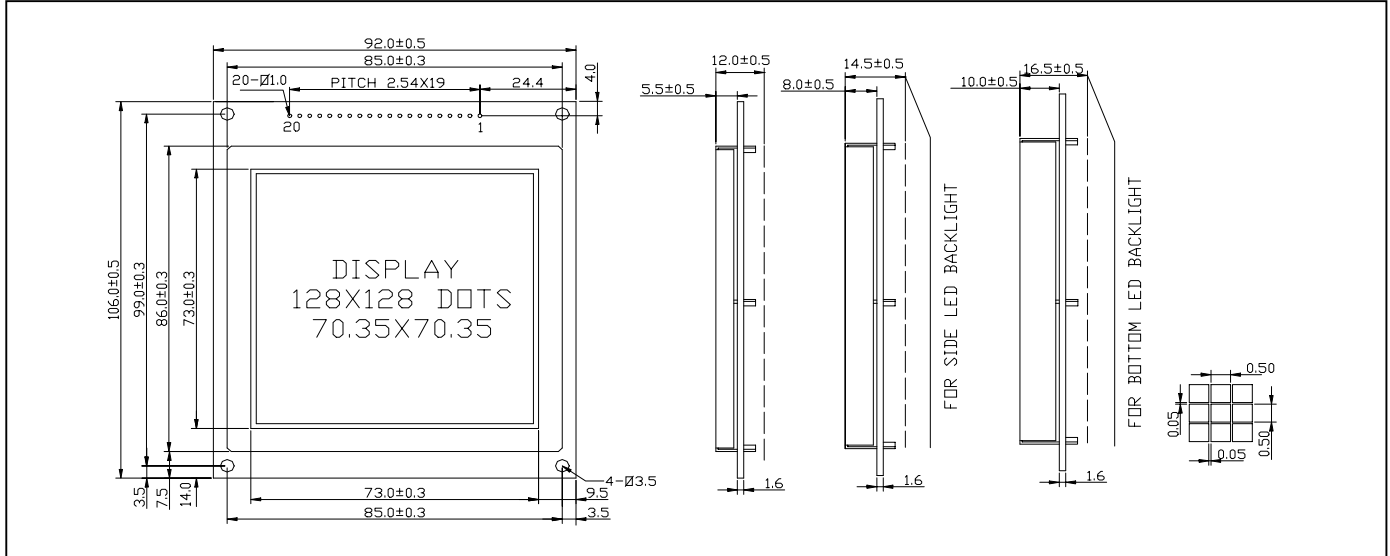

JM128128A

128DOTS×128DOTS
1/128DUTY,1/12 BIAS

1 EXTERNAL DIMENSION



2 MECHANICAL DATA

ITEM	SPECIFICATION	UNIT
Module Size (W×H×T)	92.0×106.0×12.0	mm
Viewing Area (W×H)	73.0×73.0	mm
Number of Dots(W×H)	128×128	dots
Dot Pitch (W×H)	0.55×0.55	mm
Dot Size(W×H)	0.5×0.5	mm

5 ABSOLUTE MAXIMUM RATINGS

PARAMETER	SYMBOL	MIN.	MAX.	UNIT
Supply Voltage	V _{dd}	-0.3	7.0	V
LCD Supply Voltage	V _{ee}	V _{dd} -28	V _{dd} -8	V
Input Voltage	V _r	-0.3	V _{dd} +0.3	V
Operating Temperature	Top	0	50	°C
Storage Temperature	T _{stg}	-20	70	°C

3 PIN CONNECTIONS

PIN	SYMBOL	SIGNAL DESCRIPTION
1	FG	Frame GND
2	V _{ss}	GND
3	V _{dd}	Power Supply
4	V _{ee}	Power Supply for LCD
5	WR	Write when "L"
6	RD	Read when "L"
7	CE	Enable when "L"
8	C/D	Register Select(L=DATA,H=Instruction)
9	RSTB	Reset Signal when "L"
10 to 17	DB0 to DB7	Data Bus for 8bit Mode
18	FS	Select character style 6X8 or 8X8
19	A	Anode of LED Unit
20	K	Cathode of LED Unit

6 ELECTRICAL CHARACTERISTICS(T_a=25°C)

ITEM	SYMBOL	CONDITION	MIN.	TYP.	MAX.	UNIT
Supply Voltage(logic)	V _{dd} -V _{ss}	-	4.5	5.0	5.5	V
Supply Current(logic)	I _{dd}	V _{dd} =5.0	-	4.0	-	mA
Driving Current(LCD)	I _{ee}	V _{ee} =-14.0	-	2.8	-	mA
Driving Voltage(LCD)	V _{dd} -V _{ee}	25°C	-	19.0	-	V
Input Voltage "H"	V _{IH}	H	V _{dd} -2.2	-	V _{dd}	V
Input Voltage "L"	V _{IL}	L	0	-	0.8	V
Output Voltage "H"	V _{OH}	H	V _{dd} -0.3	-	V _{dd}	V
Output Voltage "L"	V _{OL}	L	0	-	0.3	V

4 BLOCK DIAGRAM

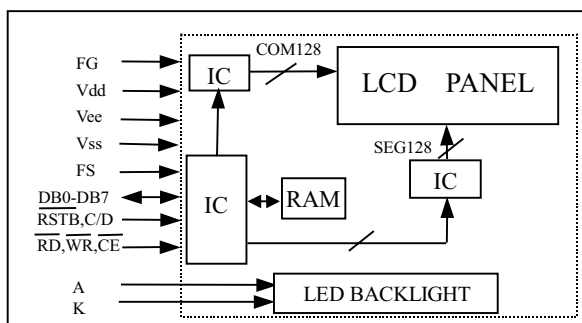

7 BACKLIGHT CHARACTERS(T_a=25°C)

PARAMETER	SYMBOL	CONDITION	MIN.	TYP.	MAX.	UNIT
Supply Voltage	V _{LED}	-	-	4.1	-	V
LED Forward Consumption Current	I _{f(Side)}	T _a =25°C V _f =4.1V	-	100	-	mA
	I _{f(Bottom)}			580		
LED Allowable Dissipation	P _{d(Side)}	-	-	410	-	mW
	P _{d(Bottom)}			2350		