

SPECIFICATION

Character Type Dot Matrix LCD Module

JM404A

● GENERAL SPECIFICATION

Interface with 4-bit or 8-bit MPU(directly connected to M6800 serial MPU)

Display Specification

Display Character: 40character X 4line Character Font: 5 X 7dots+cursor

Display type: STN ,TN

Display color-Display background color: ① STN: Black-Yellow Green,Blue-Gray
Black-White

②TN: Position,Negative

Polarizer mode: Positive,Negative;Reflective ,Transflective, Transmissive

Viewing angle: 6:00 OR 12:00

Display duty: 1/16 Driving bias: 1/5

Character Generator ROM (CGROM):8320 bits(192 characterX5X7 dots)&(32 character
X5X10 dots)

Character Generator RAM (CGRAM): 64 X 8 bits (8 charactersX5X8 dots)

Display Data RAM (DDRAM): 80X8 bits (80 characters max)

Mechanical characteristics (Unit:mm)

Extenal dimension: 196.0X56.0X10.0 (14.5 for LED Backlight)

View area: 167.0X33.0 Character font: 5X7dots+cursor

Character size: 3.45X5.98 Dots size:0.61X0.66

Character pitch: 4.04X7.00

POWER: +5V power

● **Optical Characteristics**

(1) Definition of viewing Angle

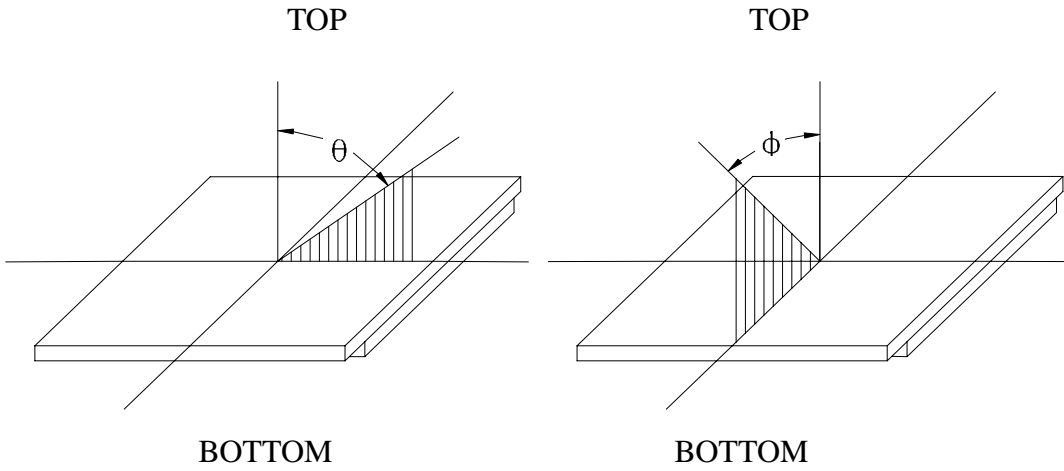

(2) Definition of Contrast Ratio:

$$\text{Contrast Ratio} = \frac{\text{Reflectance value of non-selected state brightness}}{\text{Reflectance value of selected state brightness}}$$

Test condition : standard A light source

(3) Response Time

Response time is measured as the shortest period of time possible between the change in state of an LCD segment as demonstrated below

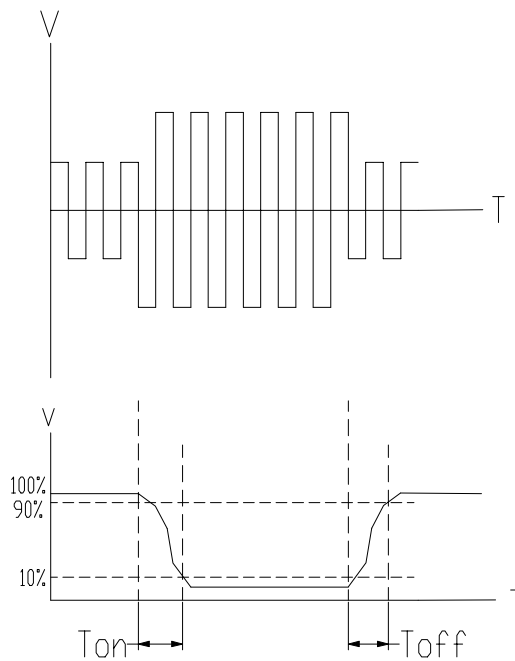

● External Dimension

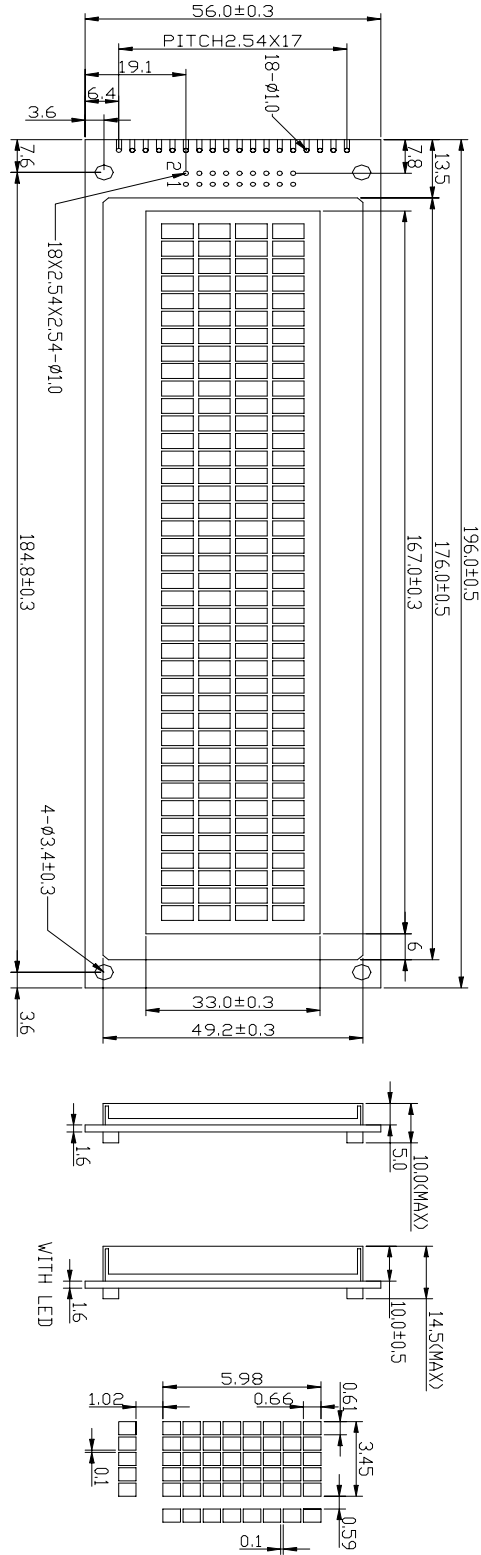

● Absolute Maximum Ratings

Item	Symbol	Condition	Standard Value		Unit
			Min	Max	
Supply Voltage for logic	Vdd	Ta=25°C	-0.3	7.0	V
Supply Voltage for LCD	V5		Vdd-15.0	Vdd+0.3	V
Input Voltage	Vi		-0.3	Vdd+0.3	V
Operating Temperature(T)	Top	-	0	50	°C
Storage Temperature(T)	Tstg	-	-20	70	°C
Operating Temperature(HT)	HTop	-	-20	70	°C
Storage Temperature(HT)	HTstg	-	-30	80	°C
Operating Temperature(EHT)	EHTop	-	-30	80	°C
Storage Temperature(EHT)	EHTstg	-	-40	80	°C

● Electrical Characteristics(Ta=25°C,Vdd=5.0V)

Item	Symbol	Condition	Standard Value			Unit
			Min	Type	Max	
Supply Voltage for logic	Vdd-GND	-	4.5	5.0	5.5	V
Supply Current for logic	Idd	Vdd=5V	-	3.0	6.0	mA
Driving Current for LCD	Iee		-	0.8	2.0	mA
Driving Voltage for LCD	Vdd-V5		3.8	4.5	4.9	V
Input Voltage H level	Vih		2.2	-	Vdd	V
Input Voltage L level	Vil		-0.3	-	0.6	V
Output Voltage “H”	Voh		Ioh=-0.205mA	2.4	-	-
Output Voltage “L”	Vol	Iol=1.2mA	-	-	0.4	V

● Absolute Maximum Ratings For LED Backlight

PARAMETER	SYMBOL	CONDITION	MIN.	TYP.	MAX.	UNIT
Supply Voltage	VLED	-	-	4.1	-	V
LED Forward Consumption Current	If	Ta=25°C Vf=4.1V	-	550	-	mA
LED Allowable Dissipation	Pd	-	-	2300	-	mW

● Block Diagram

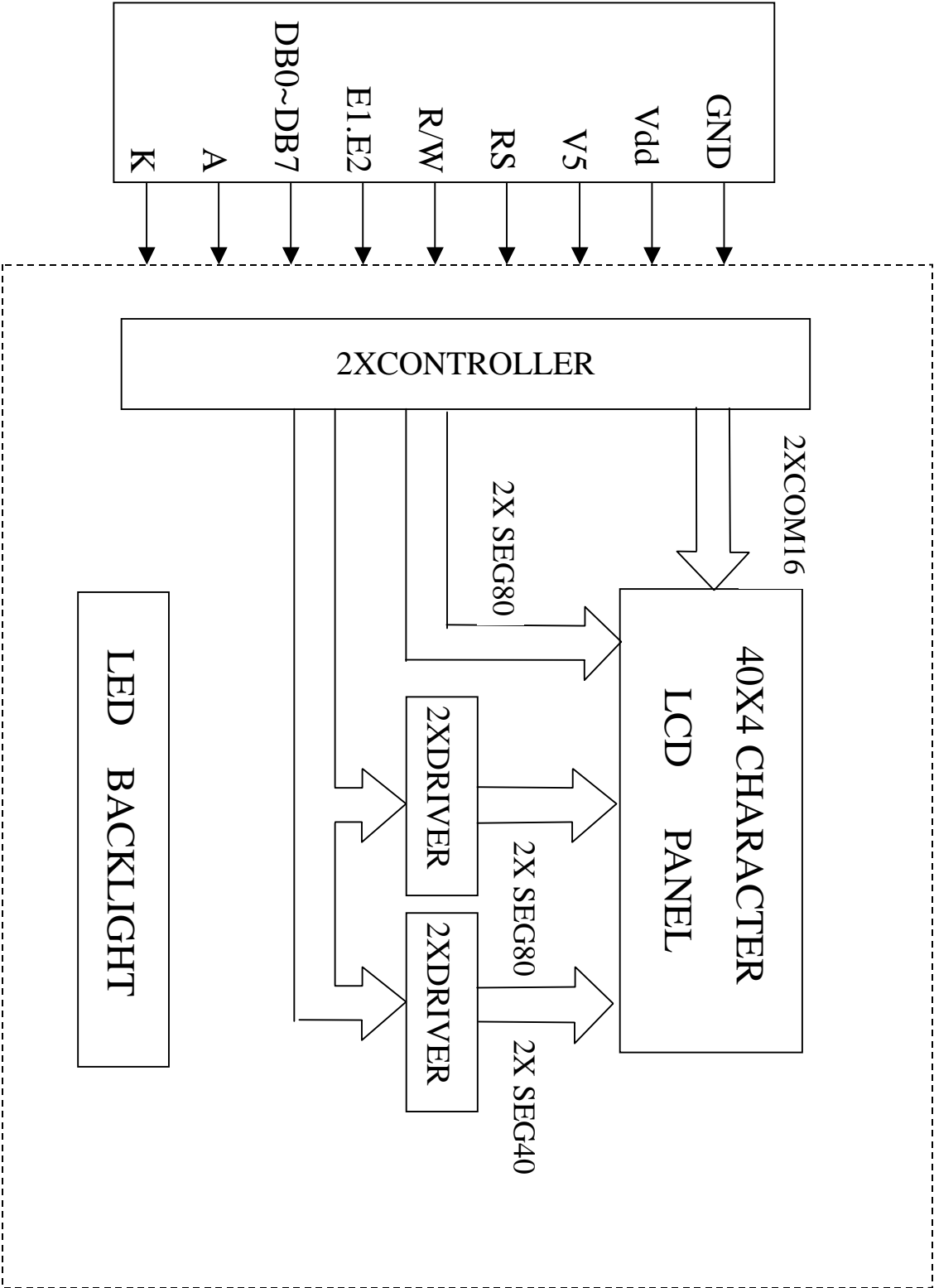

● Bus Timing

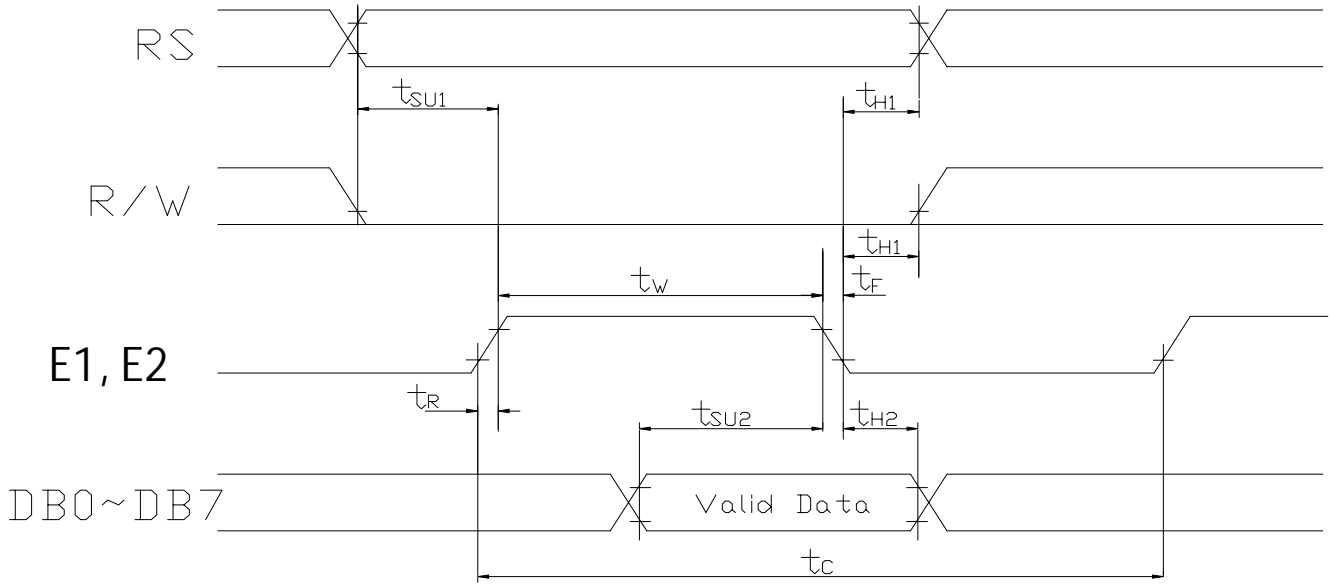

Write Mode Timing Diagram

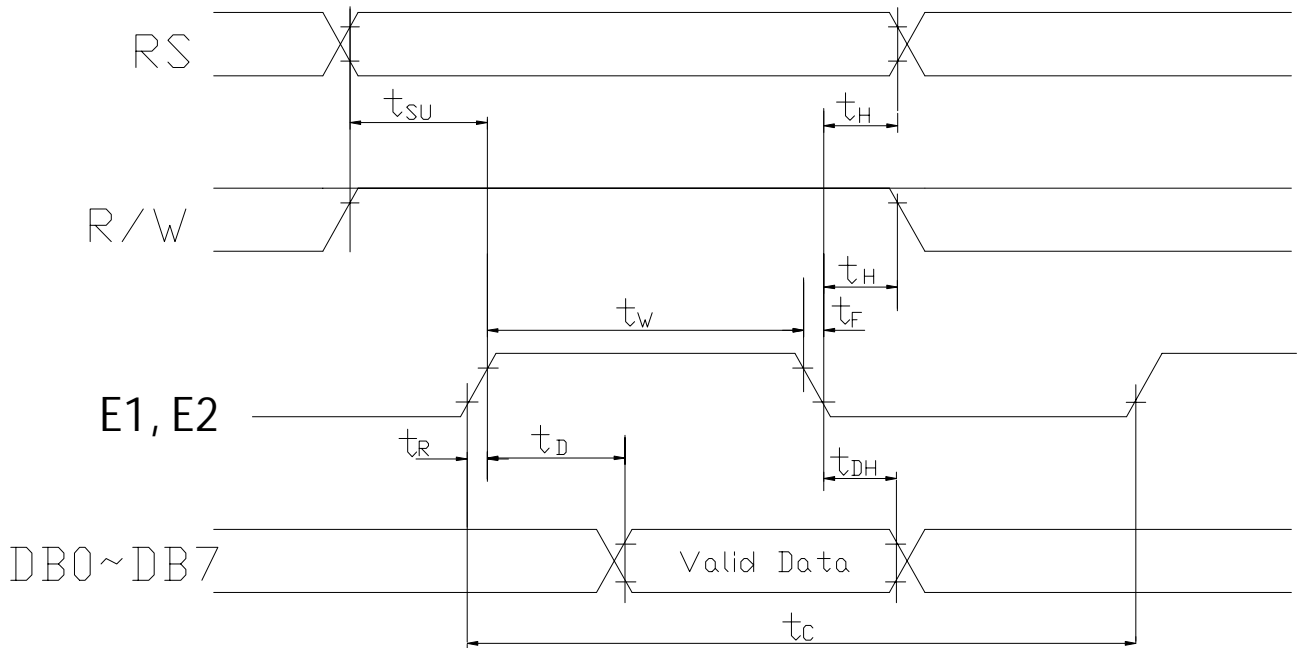

Read Mode Timing Diagram

AC Characteristics (Vdd=4.5V~5.5V,Ta=-30~+85°C)

Mode	Characteristic	Symbol	Min.	Typ.	Max.	Unit
Write Mode	E Cycle Time	t_C	500	-	-	ns
	E Rise/Fall Time	t_R, t_F	-	-	20	
	E Pulse Width (High,Low)	t_W	230	-	-	
	R/W and RS Setup Time	t_{SU1}	40	-	-	
	R/W and RS Hold Time	t_{H1}	10	-	-	
	Data Setup Time	t_{SU2}	80	-	-	
	Data Hold Time	t_{H2}	10	-	-	
Read Mode	E Cycle Time	t_C	500	-	-	ns
	E Rise/Fall Time	t_R, t_F	-	-	20	
	E Pulse Width (High,Low)	t_W	230	-	-	
	R/W and RS Setup Time	t_{SU}	40	-	-	
	R/W and RS Hold Time	t_H	10	-	-	
	Data Output Delay Time	t_D	-	-	120	
	Data Hold Time	t_{DH}	5	-	-	

● **IC Specifications**

See The Reference of Samsung Data Book-----S6A0700(KS0070B)

● Pin assignment

Pin NO.	Symbol	Function		Remark
1	GND	Power supply	0V	
2	Vdd		+5V	
3	V5		For LCD	Variable
4	RS	Register Select(H=Data,L=Instruction)		
5	R/W	Read/Write L=MPU to LCM,H=LCM to MPU		
6	NC	No connection		
7	DB0	Data bus bit 0		
8	DB1	Data bus bit 1		
9	DB2	Data bus bit 2		
10	DB3	Data bus bit 3		
11	DB4	Data bus bit 4		
12	DB5	Data bus bit 5		
13	DB6	Data bus bit 6		
14	DB7	Data bus bit 7		
15	E1	Enable controller1		
16	E2	Enable controller2		
17	A	Anode of LED Unit		
18	K	Cathode of LED Unit		

● Instruction Table

Instruction	Instruction Code										Description	Execution Time($f_{osc}=270kHz$)	
	RS	R/W	DB7	DB6	DB5	DB4	DB3	DB2	DB1	DB0			
Clear Display	0	0	0	0	0	0	0	0	0	0	1	Write"20H" to DDRAM set DDRAM address to "00H" from AC	1.53ms
Return Home	0	0	0	0	0	0	0	0	0	1	-	Set DDRAM address to "00H" from AC and return cursor to its original position if shifted. The contents of DDRAM are not changed	1.53ms
Entry Mode Set	0	0	0	0	0	0	0	0	1	I/D	SH	Assign cursor moving direction and enable the shift of entire display	39 μ s
Display ON/OFF Control	0	0	0	0	0	0	0	1	D	C	B	Set display(D) cursor(C) and blinking of cursor(B) on/off	39 μ s
Cursor or Display Shift	0	0	0	0	0	0	1	S/C	R/L	-	-	Set cursor moving and display shift control bit,and the direction, without changing DDRAM data	39 μ s
Function Set	0	0	0	0	0	1	DL	N	F	-	-	Set interface data length(DL:8bit/4bit), number of display line (N:2line/1line) and,display font type F:5X11dots / 5X8dots	39 μ s
Set CGRAM Address	0	0	0	1	AC5	AC4	AC3	AC2	AC1	AC0		Set CGRAM address in address counter	39 μ s
Set DDRAM Address	0	0	1	AC6	AC5	AC4	AC3	AC2	AC1	AC0		Set DDRAM address in address counter	39 μ s
Read Busy Flag and Address	0	1	BF	AC6	AC5	AC4	AC3	AC2	AC1	AC0		Whether during internal operation or not can be known by reading BF The contents of address counter can also be read	0 μ s
Write Data to RAM	1	0	D7	D6	D5	D4	D3	D2	D1	D0		Write data into internal RAM (DDRAM/CGRAM)	43 μ s
Read data from RAM	1	1	D7	D6	D5	D4	D3	D2	D1	D0		Read data from internal RAM (DDRAM/CGRAM)	43 μ s

● Reflector of Screen and DDRAM Address

Display position	1-1	1-2	1-3	1-4	1-5	1-6	1-7	1-8	1-9	1-10
DDRAM address	00	01	02	03	04	05	06	07	08	09
Display position	1-11	1-12	1-13	1-14	1-15	1-16	1-17	1-18	1-19	1-20
DDRAM address	0A	0B	0C	0D	0E	0F	10	11	12	13
Display position	1-21	1-22	1-23	1-24	1-25	1-26	1-27	1-28	1-29	1-30
DDRAM address	14	15	16	17	18	19	1A	1B	1C	1D
Display position	1-31	1-32	1-33	1-34	1-35	1-36	1-37	1-38	1-39	1-40
DDRAM address	1E	1F	20	21	22	23	24	25	26	27
Display position	2-1	2-2	2-3	2-4	2-5	2-6	2-7	2-8	2-9	2-10
DDRAM address	40	41	42	43	44	45	46	47	48	49
Display position	2-11	2-12	2-13	2-14	2-15	2-16	2-17	2-18	2-19	2-20
DDRAM address	4A	4B	4C	4D	4E	4F	50	51	52	53
Display position	2-21	2-22	2-23	2-24	2-25	2-26	2-27	2-28	2-29	2-30
DDRAM address	54	55	56	57	58	59	5A	5B	5C	5D
Display position	2-31	2-32	2-33	2-34	2-35	2-36	2-37	2-38	2-39	2-40
DDRAM address	5E	5F	60	61	62	63	64	65	66	67

“1-1” means first character of line 1 on screen, other two lines on same

● Instruction Description

A. Clear Display

RS	R/W	DB7	DB6	DB5	DB4	DB3	DB2	DB1	DB0
0	0	0	0	0	0	0	0	0	1

Clear all the display data by writing “20H”(space code) to all DDRAM address, and set DDRAM address to “00H” into AC(address counter).

Return cursor to the original status, namely, bring the cursor to the left edge on the first line of the display.

Make the entry mode increment(I/D=“High”).

B. Return Home

RS	R/W	DB7	DB6	DB5	DB4	DB3	DB2	DB1	DB0
0	0	0	0	0	0	0	0	1	-

Set DDRAM address to “00H” into the address counter.

Return cursor to its original site and return display to its original status,if shifted.

Contents of DDRAM does not change.

C. Entry Mode Set

RS	R/W	DB7	DB6	DB5	DB4	DB3	DB2	DB1	DB0
0	0	0	0	0	0	0	1	I/D	SH

Set the moving direction of cursor and display.

I/D:Increment /decrement of DDRAM address(cursor or blink)

I/D=High,cursor/blink moves to right and DDRAM address is increased by 1.

I/D=low,cursor/blink moves to left and DDRAM address is decreased by 1.

*CGRAM operates the same way as DDRAM, when reading from or writing to CGRAM.

SH:Shift of entire display

When DDRAM read (CGRAM read/write) operation or SH=Low,shifting of entire display is not performed.if SH=High, and DDRAM write operation,shift of entire display is performed according to I/D value(I/D=High,shift left,I/D=Low, shift right).

D. Display ON/OFF Control

RS	R/W	DB7	DB6	DB5	DB4	DB3	DB2	DB1	DB0
0	0	0	0	0	0	1	D	C	B

D:Display ON/OFF control bit

When D=High, entire display is turned on.

When D=Low, display is turned off,but display data remains in DDRAM.

C:Cursor ON/OFF control bit

When C=High, cursor is turned on.

When C=Low, cursor is disappeared in current display ,but I/D register preserves its data.

B:Cursor Blink ON/OFF control bit

When B=High, cursor blink is on, which performs alternately between all the “High” data and display characters at the cursor position.

When B=Low ,blink is off.

E. Cursor or Display Shift

RS	R/W	DB7	DB6	DB5	DB4	DB3	DB2	DB1	DB0
0	0	0	0	0	1	S/C	R/L	-	-

Shifting of right/left cursor position or display without writing or reading of display data.

This instruction is used to correct or search display data.

During 2-line mode display,cursor moves to the 2nd line after the 40th digit of the 1st line.

Note that display shift is performed simultaneously in all the lines.

When displayed data is shifted repeatedly,each line is shifted individually.

When display shift is performed,the contents of the address counter are not changed.

S/C	R/L	Operation
0	0	Shift cursor to the left, AC is decreased by1
0	1	Shift cursor to the right, AC is increased by1
1	0	Shift all the display to the left,cursor moves according to the display
1	1	Shift all the display to the right,cursor moves according to the display

F. Function set

RS	R/W	DB7	DB6	DB5	DB4	DB3	DB2	DB1	DB0
0	0	0	0	1	DL	N	F	-	-

DL:Interface data length control bit

When DL=High, it means 8-bit bus mode with MPU.

When DL=Low, it means 4-bit bus mode with MPU.

When 4-bit bus mode, it needs to transfer 4-bit data twice.

N:Display line number control bit

When N=Low, 1-line display mode is set.

When N=High, 2-line display mode is set.

F:Display font type control bit

When F=Low, 5x8 dots format display mode is set.

When F=High, 5x11 dots format display mode.

G. Set CGRAM Address

RS	R/W	DB7	DB6	DB5	DB4	DB3	DB2	DB1	DB0
0	0	0	1	AC5	AC4	AC3	AC2	AC1	AC0

Set CGRAM address to AC.

This instruction makes CGRAM data available from MPU.

H. Set DDRAM Address

RS	R/W	DB7	DB6	DB5	DB4	DB3	DB2	DB1	DB0
0	0	1	AC6	AC5	AC4	AC3	AC2	AC1	AC0

Set DDRAM address to AC.

This instruction makes DDRAM data available from MPU.

When 1-line display mode(N=Low),DDRAM address is from “00H” to “4FH”.

In 2-line display mode(N=High),DDRAM address in the 1st line is from “00H” to “27H”,and DDRAM address in the 2nd line is from “40H” to “67H”.

I. Read Busy Flag & Address

RS	R/W	DB7	DB6	DB5	DB4	DB3	DB2	DB1	DB0
0	1	BF	AC6	AC5	AC4	AC3	AC2	AC1	AC0

This instruction shows whether IC is in internal operation or not .

If BF is “High”,internal operation is in progress and should wait until BF is to be Low,which by then the next instruction can be performed. In this instruction you can also read the value of the address counter.

J. Write data to RAM

RS	R/W	DB7	DB6	DB5	DB4	DB3	DB2	DB1	DB0
1	0	D7	D6	D5	D4	D3	D2	D1	D0

Write binary 8-bit data to DDRAM/CGRAM.

The selection of RAM from DDRAM, and CGRAM, is set by the previous address set instruction (DDRAM address set, CGRAM address set).

RAM set instruction can also determine the AC direction to RAM.

After write operation, the address is automatically increased /decreased by 1, according to the entry mode.

K. Read data from RAM

RS	R/W	DB7	DB6	DB5	DB4	DB3	DB2	DB1	DB0
1	1	D7	D6	D5	D4	D3	D2	D1	D0

Read binary 8-bit data from DDRAM/CGRAM.

The selection of RAM is set by the previous address set instruction. If the address set instruction of RAM is not performed before this instruction, the data that has been read first is invalid, as the direction of AC is not yet determined. If RAM data is read several times without RAM address instructions set before read operation, the correct RAM data can be obtained from the second. But the first data would be incorrect, as there is no time margin to transfer RAM data.

In case of DDRAM read operation, cursor shift instruction plays the same role as DDRAM address set instruction, it also transfers RAM data to output data register.

After read operation, address counter is automatically increased/decreased by 1 according to the entry mode.

After CGRAM read operation, display shift may not be executed correctly.

Note: In case of RAM write operation, AC is increased/decreased by 1 as in read operation.

At this time, AC indicates the next address position, but only the previous data can be read by the read instruction.

● Display Data RAM(DDRAM)

DDRAM stores display data of maximum 80x8 bits(80 characters).

DDRAM address is set in the address counter(AC) as a hexadecimal number

MSB						LSB	
AC6	AC5	AC4	AC3	AC2	AC1	AC0	

● Relationship between Character Code and CGRAM

Character code									CGRAM Address						CGRAM Data								Pattern number
D7	D6	D5	D4	D3	D2	D1	D0	A5	A4	A3	A2	A1	A0	P7	P6	P5	P4	P3	P2	P1	P0		
0	0	0	0	x	0	0	0	0	0	0	0	0	0	x	x	x	0	1	1	1	0	pattern 1	
											0	0	1	x	x	x	1	0	0	0	1		
											0	1	0	x	x	x	1	0	0	0	1		
											0	1	1	x	x	x	1	1	1	1	1		
											1	0	0	x	x	x	1	0	0	0	1		
											1	0	1	x	x	x	1	0	0	0	1		
											1	1	0	x	x	x	1	0	0	0	1		
											1	1	1	x	x	x	0	0	0	0	0		
⋮									⋮						⋮								⋮
0	0	0	0	x	1	1	1	0	0	0	0	0	0	x	x	x	1	0	0	0	1	pattern8	
											0	0	1	x	x	x	1	0	0	0	1		
											0	1	0	x	x	x	1	0	0	0	1		
											0	1	1	x	x	x	1	1	1	1	1		
											1	0	0	x	x	x	1	0	0	0	1		
											1	0	1	x	x	x	1	0	0	0	1		
											1	1	0	x	x	x	1	0	0	0	1		
											1	1	1	x	x	x	0	0	0	0	0		

● Initializing Flowchart(Condition:fosc=270KHZ)

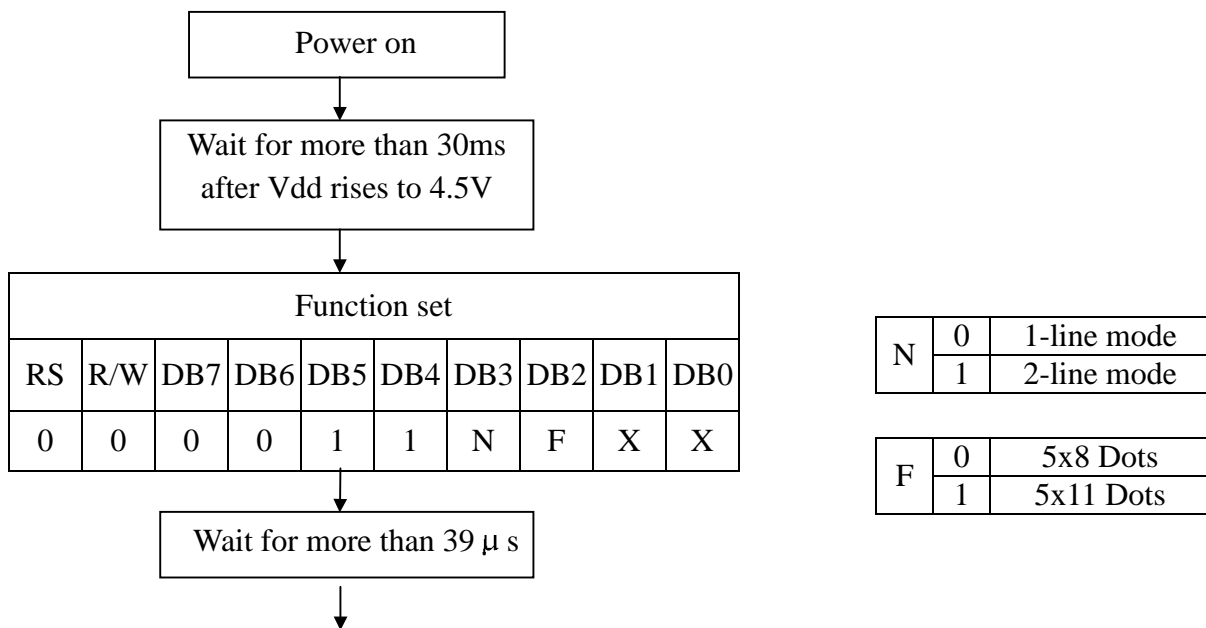

Display ON/OFF Control									
RS	R/W	DB7	DB6	DB5	DB4	DB3	DB2	DB1	DB0
0	0	0	0	0	0	1	D	C	B

Wait for more than 39 μ s

Display Clear									
RS	R/W	DB7	DB6	DB5	DB4	DB3	DB2	DB1	DB0
0	0	0	0	0	0	0	0	0	1

Wait for more than 1.53mS

Entry Mode Set									
RS	R/W	DB7	DB6	DB5	DB4	DB3	DB2	DB1	DB0
0	0	0	0	0	0	0	1	I/D	SH

Initialization End

D	0	Display off
	1	Display on

C	0	Cursor off
	1	Cursor on

B	0	Blink off
	1	Blink on

I/D	0	Decrement mode
	1	Increment mode

SH	0	Entire shift off
	1	Entire shift on

● Application Example

Application Circuit

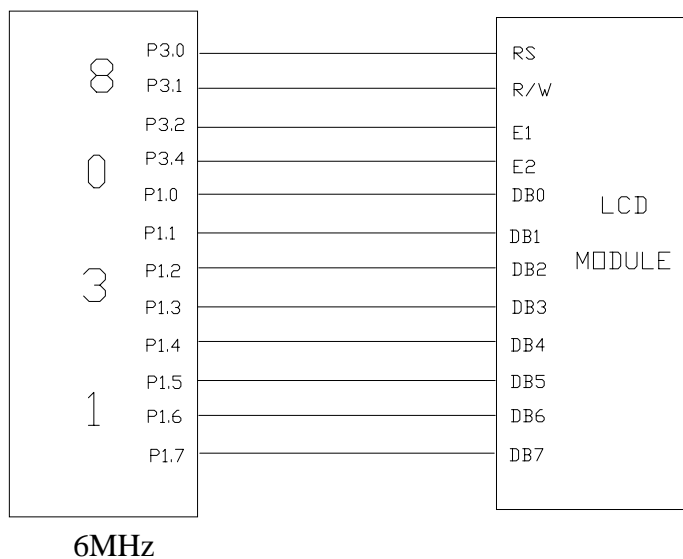

Application Flowchart

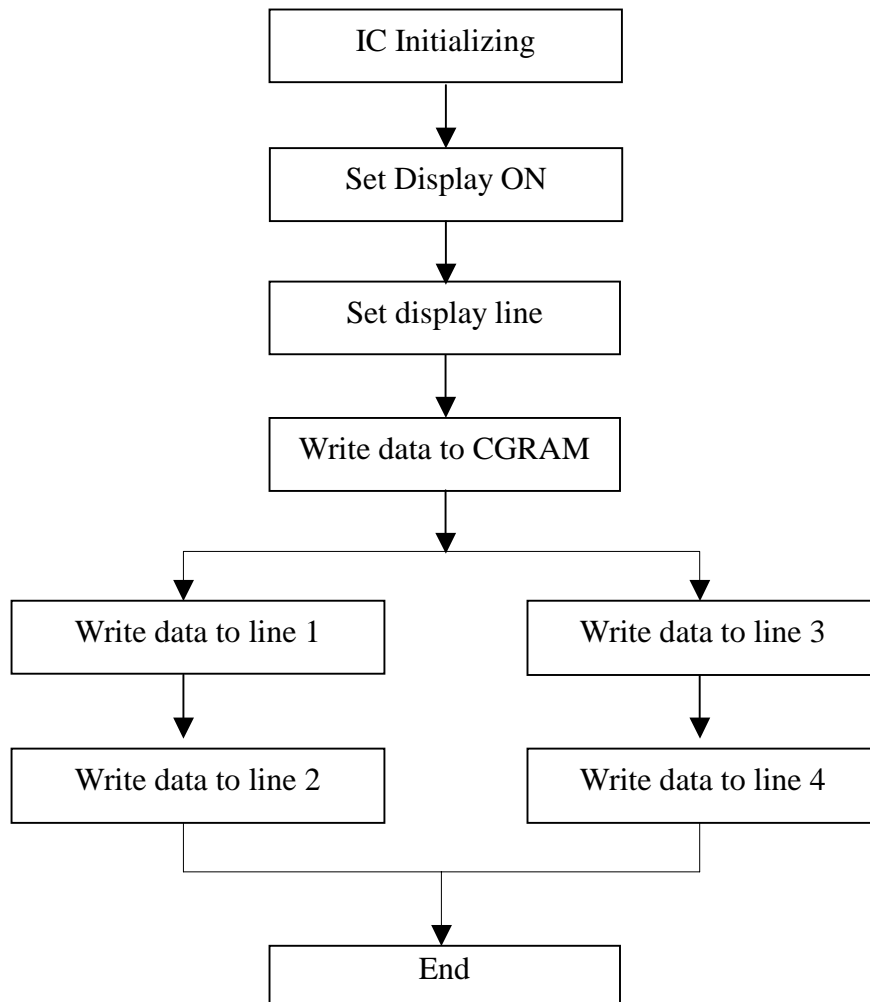

● Program Example

```

ORG 0000H
MAIN: MOV P1,#00H
      CLR P3.0
      CLR P3.1
      CLR P3.2
      CLR P3.4
      LCALL INST0      ;IC Initializing,Set interface data length(8bit),numbers of
                      ;display line (1line)and ,display font type(5X8dots)

      LCALL OPRN      ;Set display ON
      LCALL INST1      ;Set numbers of display line (2lines)
      LCALL CGRAM      ;Write data to CGRAM
  
```

```
MAIN:  MOV 30H,#0AH
        MOV 31H,#0AH
        LCALL MAIN1      ;Call main program
        LJMP MAIN
INST0:  MOV R1,#03H      ; IC Initialed subprogram
ABC:    CLR P3.0
        CLR P3.1
        SETB P3.2
        MOV A,#30H
        MOV P1,A
        CLR P3.2
        LCALL T2
        DJNZ R1,ABC
        RET
OPRN:   CLR P3.0        ; Display ON subprogram
        CLR P3.1
        MOV A,#0CH
        MOV P1,A
        LCALL WRITE
        RET
INST1:  CLR P3.0        ;Set numbers of display line (2lines) subprogram
        CLR P3.1
        MOV A,#38H
        MOV P1,A
        LCALL WRITE
        RET
CGRAM: CLR P3.0        ; Write data to CGRAM subprogram
        CLR P3.1
        MOV A,#40H
        MOV P1,A
        LCALL WRITE
        MOV R1,#20H
        SETB P3.0
        CLR P3.1
        MOV DPTR,#TAB2
X1:     CLR A
        MOVC A,@A+DPTR
        MOV P1,A
        LCALL WRITE
        INC DPTR
```

```
DJNZ R1,X1
RET
MAIN1: MOV DPTR,#TAB1      ;Display TAB1 on screen
      MOV R1,30H
      MOV R2,31H
      LCALL LINE1
      LCALL LINE2
      LCALL T3
      MOV DPTR,#TAB7      ;Display TAB7 on screen
      MOV R1,30H
      MOV R2,31H
      LCALL LINE1
      LCALL LINE2
      LCALL T3
      MOV DPTR,#TAB8      ;Display TAB8 on screen
      MOV R1,30H
      MOV R2,31H
      LCALL LINE1
      LCALL LINE2
      LCALL T3
      MOV DPTR,#TAB9      ;Display TAB9 on screen
      MOV R1,30H
      MOV R2,31H
      LCALL LINE1
      LCALL LINE2
      LCALL T3
      MOV DPTR,#TAB10     ;Display TAB10 on screen
      MOV R1,30H
      MOV R2,31H
      LCALL LINE1
      LCALL LINE2
      LCALL T3
      MOV DPTR,#TAB11     ;Display TAB11 on screen
      MOV R1,30H
      MOV R2,31H
      LCALL LINE1
      LCALL LINE2
      LCALL T3
      RET
LINE1: CLR P3.0           ;Write data to line 1
```

```

        CLR P3.1
        MOV A,#80H
        MOV P1,A
        LCALL WRITE           ;Set DDRAM address
        SETB P3.0
        CLR P3.1
N1:    MOV R0,#04H
L1:    CLR A
        MOVC A,@A+DPTR
        MOV P1,A
        LCALL WRITE           ;Write data to DDRAM
        INC DPTR
        DJNZ R0,L1
        DJNZ R1,N1
        RET
LINE2: CLR P3.0               ;Write data on line 2
        CLR P3.1
        MOV A,#0C0H
        MOV P1,A
        LCALL WRITE           ;Set DDRAM address
        CLR P3.1
        SETB P3.0
N2:    MOV R0,#04H
L2:    CLR A
        MOVC A,@A+DPTR
        MOV P1,A
        LCALL WRITE           ;Write data to DDRAM
        INC DPTR
        DJNZ R0,L2
        DJNZ R2,N2
        RET
WRITE: SETB P3.2               ;Write subprogram
        SETB P3.4
        MOV R7,#01H
AB:    MOV R6,#0FFH
AC:    DJNZ R6,AC
        DJNZ R7,AB
        CLR P3.2
        CLR P3.4
        RET
    
```

```

T1:    MOV R7,#40H           ;Delay subprogram 1
AD:    MOV R6,#0FFH
AE:    DJNZ R6,AE
       DJNZ R7,AD
       RET

T2:    MOV R7,#20H           ;Delay subprogram 2
AF:    MOV R6,#0FFH
AG:    DJNZ R6,AG
       DJNZ R7,AF
       RET

T3:    MOV R7,#03H           ;Delay subprogram 3
AH:    MOV R6,#8FH
AI:    MOV R5,#0FFH
AJ:    DJNZ R5,AJ
       DJNZ R6,AI
       DJNZ R7,AH
       RET

TAB1:  DB 0FFH,0FFH,0FFH,0FFH,0FFH,0FFH,0FFH,0FFH
       DB 0FFH,0FFH,0FFH,0FFH,0FFH,0FFH,0FFH,0FFH
       DB 0FFH,0FFH,0FFH,0FFH,0FFH,0FFH,0FFH,0FFH
       DB 0FFH,0FFH,0FFH,0FFH,0FFH,0FFH,0FFH,0FFH
       DB 0FFH,0FFH,0FFH,0FFH,0FFH,0FFH,0FFH,0FFH
       DB 0FFH,0FFH,0FFH,0FFH,0FFH,0FFH,0FFH,0FFH
       DB 0FFH,0FFH,0FFH,0FFH,0FFH,0FFH,0FFH,0FFH
       DB 0FFH,0FFH,0FFH,0FFH,0FFH,0FFH,0FFH,0FFH
       DB 0FFH,0FFH,0FFH,0FFH,0FFH,0FFH,0FFH,0FFH
       DB 0FFH,0FFH,0FFH,0FFH,0FFH,0FFH,0FFH,0FFH

TAB2:  DB 1FH,00H,1FH,00H,1FH,00H,1FH,00H
       DB 00H,1FH,00H,1FH,00H,1FH,00H,1FH
       DB 15H,15H,15H,15H,15H,15H,15H,15H
       DB 0AH,0AH,0AH,0AH,0AH,0AH,0AH,0AH

TAB7:  DB 00H,00H,00H,00H,00H,00H,00H,00H
       DB 00H,00H,00H,00H,00H,00H,00H,00H
       DB 00H,00H,00H,00H,00H,00H,00H,00H
       DB 00H,00H,00H,00H,00H,00H,00H,00H
       DB 00H,00H,00H,00H,00H,00H,00H,00H
       DB 00H,00H,00H,00H,00H,00H,00H,00H
       DB 00H,00H,00H,00H,00H,00H,00H,00H
       DB 00H,00H,00H,00H,00H,00H,00H,00H
       DB 00H,00H,00H,00H,00H,00H,00H,00H

```

TAB8: DB 00H,00H,00H,00H,00H,00H,00H,00H
DB 01H,01H,01H,01H,01H,01H,01H,01H
DB 01H,01H,01H,01H,01H,01H,01H,01H
DB 01H,01H,01H,01H,01H,01H,01H,01H
DB 01H,01H,01H,01H,01H,01H,01H,01H
DB 01H,01H,01H,01H,01H,01H,01H,01H
DB 01H,01H,01H,01H,01H,01H,01H,01H
DB 01H,01H,01H,01H,01H,01H,01H,01H
DB 01H,01H,01H,01H,01H,01H,01H,01H
DB 01H,01H,01H,01H,01H,01H,01H,01H
DB 01H,01H,01H,01H,01H,01H,01H,01H

TAB9: DB 02H,03H,02H,03H,02H,03H,02H,03H
DB 02H,03H,02H,03H,02H,03H,02H,03H
DB 02H,03H,02H,03H,02H,03H,02H,03H
DB 02H,03H,02H,03H,02H,03H,02H,03H
DB 02H,03H,02H,03H,02H,03H,02H,03H
DB 02H,03H,02H,03H,02H,03H,02H,03H
DB 02H,03H,02H,03H,02H,03H,02H,03H
DB 02H,03H,02H,03H,02H,03H,02H,03H
DB 02H,03H,02H,03H,02H,03H,02H,03H
DB 02H,03H,02H,03H,02H,03H,02H,03H
DB 02H,03H,02H,03H,02H,03H,02H,03H

TAB10: DB 03H,02H,03H,02H,03H,02H,03H,02H
DB 03H,02H,03H,02H,03H,02H,03H,02H
DB 03H,02H,03H,02H,03H,02H,03H,02H
DB 03H,02H,03H,02H,03H,02H,03H,02H
DB 03H,02H,03H,02H,03H,02H,03H,02H
DB 03H,02H,03H,02H,03H,02H,03H,02H
DB 03H,02H,03H,02H,03H,02H,03H,02H
DB 03H,02H,03H,02H,03H,02H,03H,02H
DB 03H,02H,03H,02H,03H,02H,03H,02H
DB 03H,02H,03H,02H,03H,02H,03H,02H
DB 03H,02H,03H,02H,03H,02H,03H,02H

TAB11: DB 31H,32H,33H,34H,35H,36H,37H,38H
DB 39H,41H,42H,43H,44H,45H,46H,47H
DB 31H,32H,33H,34H,35H,36H,37H,38H
DB 39H,41H,42H,43H,44H,45H,46H,47H
DB 31H,32H,33H,34H,35H,36H,37H,38H
DB 39H,41H,42H,43H,44H,45H,46H,47H
DB 31H,32H,33H,34H,35H,36H,37H,38H
DB 39H,41H,42H,43H,44H,45H,46H,47H
DB 31H,32H,33H,34H,35H,36H,37H,38H

DB 39H,41H,42H,43H,44H,45H,46H,47H
END

● Application Circuit 1

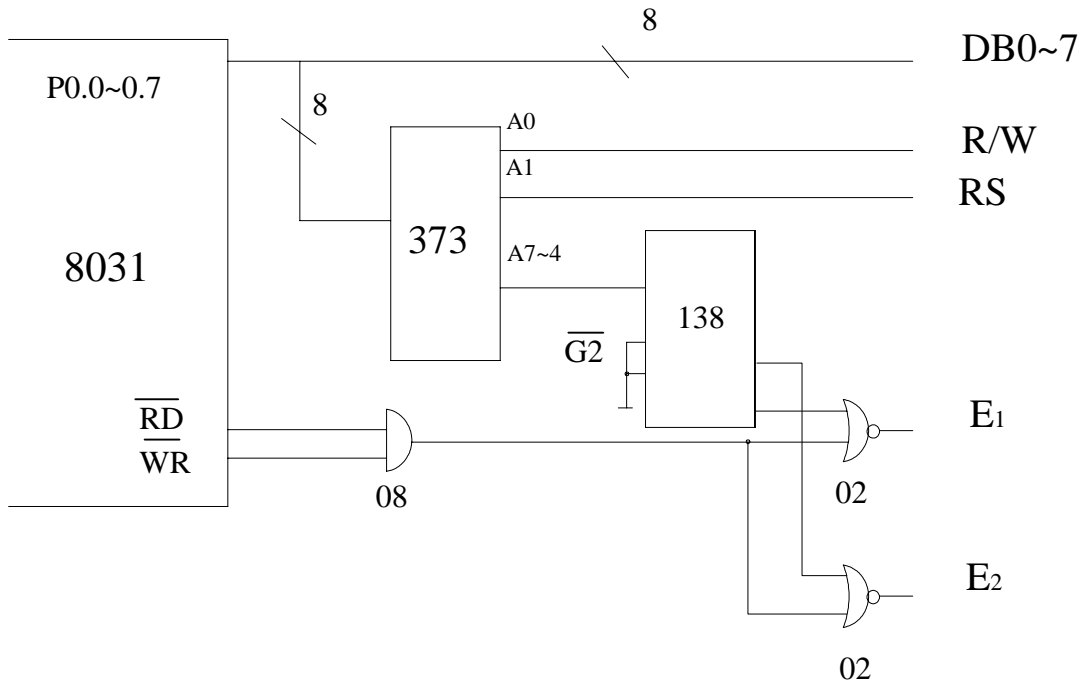

● Application Circuit 2

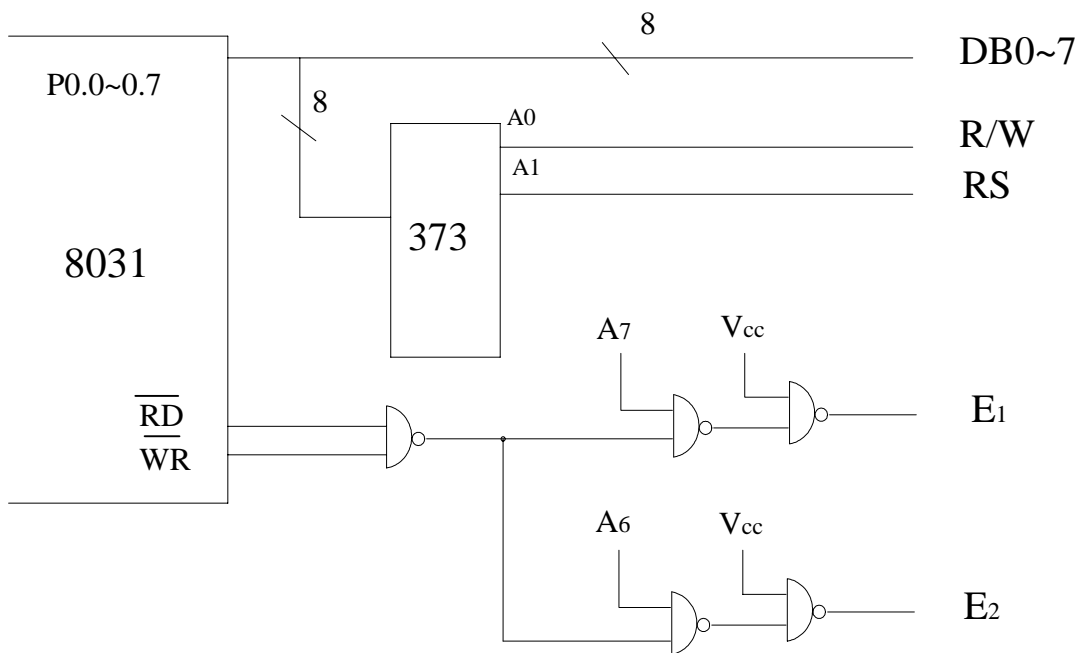

● Character Generator ROM(ROM CODE 00)

Upper 4bit Lower 4bit	LLLL	LLLH	LLHL	LLHH	LHLL	LHLH	LHHL	LHHH	HLLL	HLLH	HLHL	HLHH	HHLL	HHLH	HHHL	HHHH
LLLL	CG RAM (1)															
LLLH	(2)															
LLHL	(3)															
LLHH	(4)															
LHLL	(5)															
LHLH	(6)															
LHHL	(7)															
LHHH	(8)															
HLLL	(1)															
HLLH	(2)															
HLHL	(3)															
HLHH	(4)															
HHLL	(5)															
HHLH	(6)															
HHHL	(7)															
HHHH	(8)															